



Power Base E27-V2 (E27) Benefits:

- **High Light Output**
- Extremely Low Operation Cost / Energy Efficient (4W VS 15W)
- Natural Illumination/ **Non-Flickering**
- **Firm Heat Dissipation**
- Super Long Life / Zero Maintenance
- Simple Design / Solid Construct
- **Constant Current Design**
- Environmentally Friendly / No Toxic / Reduce Waste
- Application: All Indoor Lighting E27

Power Base E27-V2

FPB12-W01HP-RA4 (White, 60°)
 FPB12-WW01HP-RA4 (Warm White, 60°)



Specification Features

Color Range	White, Warm White
Dimensions	Φ50mm x H83mm
Light Source	3W CREE High Power LED
Housing	Aluminum
Operating Temperature	-20°C to 50°C (-4°F to 122°F)
Starting Temperature	-10°C to 50°C (14°F to 122°F)
IP Rating	IP40
LED source life	50, 000 hours
Base	E27 standard screw base
Accessory	None
Weight	100g

Physical Dimensions

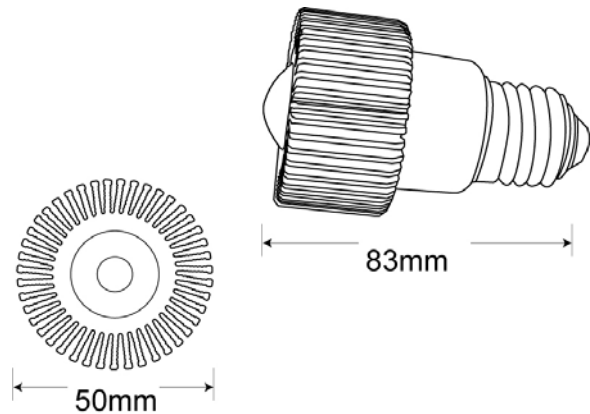

Electrical

Power Input	AC 110V/240V	Control Mechanism	None
DC Current	700mA	Controller	None
Power Consumption	4W	Data Wiring	None

Optical

Lens	Polycarbonate
Beam Angle	60°
Light Distribution	Symmetric direct illumination

Light Output

Color	Wavelength (nm)	Color Temp. (Typical)	Power Consumption (W)	Light Output (Lm)	Efficacy (Lm/W)
White	-	5500~6000K	4	120	48.98
Warm White	-	2800~3200K	4	100	40.81