



Power Base MR16 5W Benefits:

- **High Light Output**
- Extremely Low Operation Cost / Energy Efficient (5W VS 50W)
- Natural Illumination/ **Non-Flickering**
- **Firm Heat Dissipation**
- Super Long Life / Zero Maintenance
- Simple Design / Solid Construct
- **Constant Current Design**
- Environmentally Friendly / No Toxic / Reduce Waste
- Application: All Indoor Lighting GU5.3/MR16

Power Base MR16 5W

FPB15W05HPPD5 (White, 30°)
 FPB15WW05HPPD5 (Warm White, 30°)

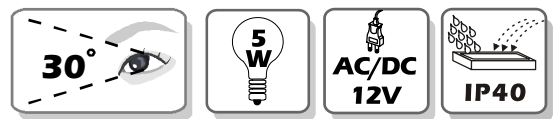

Specification Features

Color Range	White, Warm White
Dimensions	Φ49.5mm x H51mm
Light Source	5pcs*1W High Power LED
Housing	Aluminum
Operating Temperature	-20°C to 50°C (-4°F to 122°F)
Starting Temperature	-10°C to 50°C (14°F to 122°F)
IP Rating	IP40
LED source life	50,000 hours
Base	MR16
Accessory	None
Weight	35g

Physical Dimensions

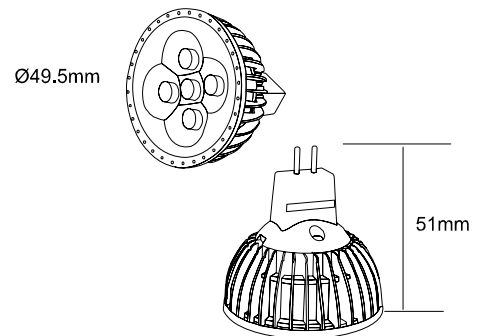

Electrical

Power Input	AC 12V / DC 12V	Control Mechanism	None
DC Current	250mA	Controller	None
Power Consumption	5W	Data Wiring	None

Optical

Lens	Polycarbonate
Beam Angle	30°
Light Distribution	Symmetric direct illumination

Light Output

Color	Wavelength (nm)	Color Temp. (Typical)	Power Consumption (W)	Light Output (Lm)	Efficacy (Lm/W)
White	-	5500~6000K	5	400	80
Warm White	-	2800~3200K	5	325	65